

JDN BIG BAG HANDLING AIR HOISTS

Dimensions

Type	A	B	C	D	E	F	G	H	J	K	M	N	P	R
BBH1000	360	163	182	227	185	95	159	388	192	1100	28	250	70	116
BBH2000	360	220	182	227	185	95	159	426	220	1100	30	250	70	116

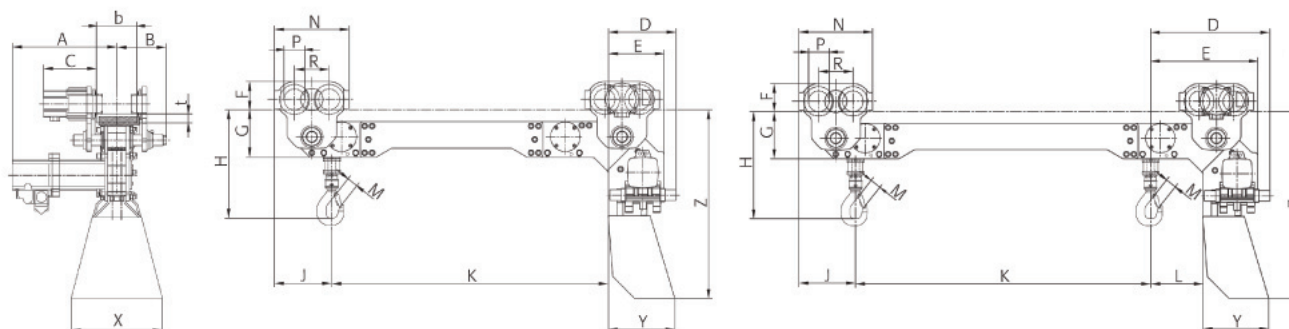

Specifications

Type		BBH 1000-1	BBH2000-1	BBH 1000-2	BBH 2000-2
Number of hooks		1	1	2	2
Air pressure	bar	6	6	6	6
Rated Capacity	tonne	1	2	1	2
Number of chain strands		1	2	2	4
Engine output hoist	kW	1	1	1	1
Engine output trolley	kW	0.2	0.2	0.2	0.2
Lifting Speed Full Load	m/min	4	2	4	2
Lowering Speed at full load	m/min	10	5	10	5
Air Consumption at full load	m3/min	1.4	1.4	1.4	1.4
Weight at standard lift and minimum k dimension	kg	130	137	137	149
Chain Dimension	mm	7x21	7x21	7x21	7x21
Weight of 1m chain	kg	1	1	1	1
Standard Lift	m	3	3	3	3
Length of control at standard load	m	2	2	2	2
Noise level at full load	db	76	76	76	76

