

JDN MINI AIR HOIST

Dimensions

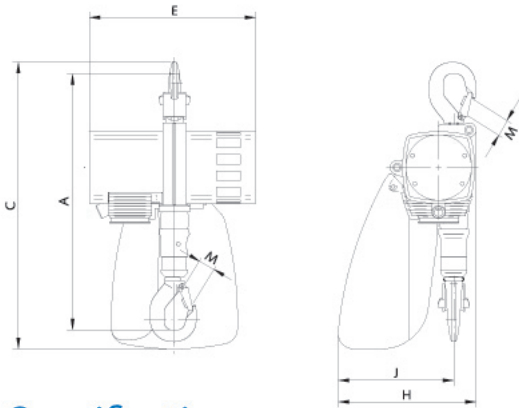

Model	MINI125	MINI250	MINI500	MINI1000
Dimensions mm C	232	232	316	316
E	213	213	292	292
H	177	177	238	234
J	148	148	194	194
M	19	19	28	28
Headroom A	328	328	458	458

Specifications

Model	MINI125	MINI250	MINI500	MINI1000
Rated Capacity kg	125	250	500	100
Stock code	JDN123	JDN253	JDN503	JDN603
Weight at standard 3m lift kg	9.5	10.5	21	23
Motor output kW	0.4	0.4	1.0	1.0
Chain dimension mm	4x12	4x12	7x21	7x21
Air pressure bar	6	6	6	6
Air consumption at full load m ³ /min				
Lifting	0.5	0.5	1.2	1.2
Lowering	0.7	0.7	1.6	1.6
Air connection	G ³ / ₈	G ³ / ₈	G ¹ / ₂	G ¹ / ₂
Lifting speed at full load m/min	15	8	10	5
Lowering speed at full load m/min	30	16	18	10

* Custom lift heights also available. Weight and headroom based on Mini standard model with pendant control and chain bucket.



43 SPENCER STREET, JANDAKOT WA 6164 TEL: (08) 9417 9128 FAX: (08) 9417 4105
 EMAIL: INFO@VECTORLIFTING.COM.AU WEBSITE: WWW.VECTORLIFTING.COM.AU